

Alternate
2-Part Tooth Configuration

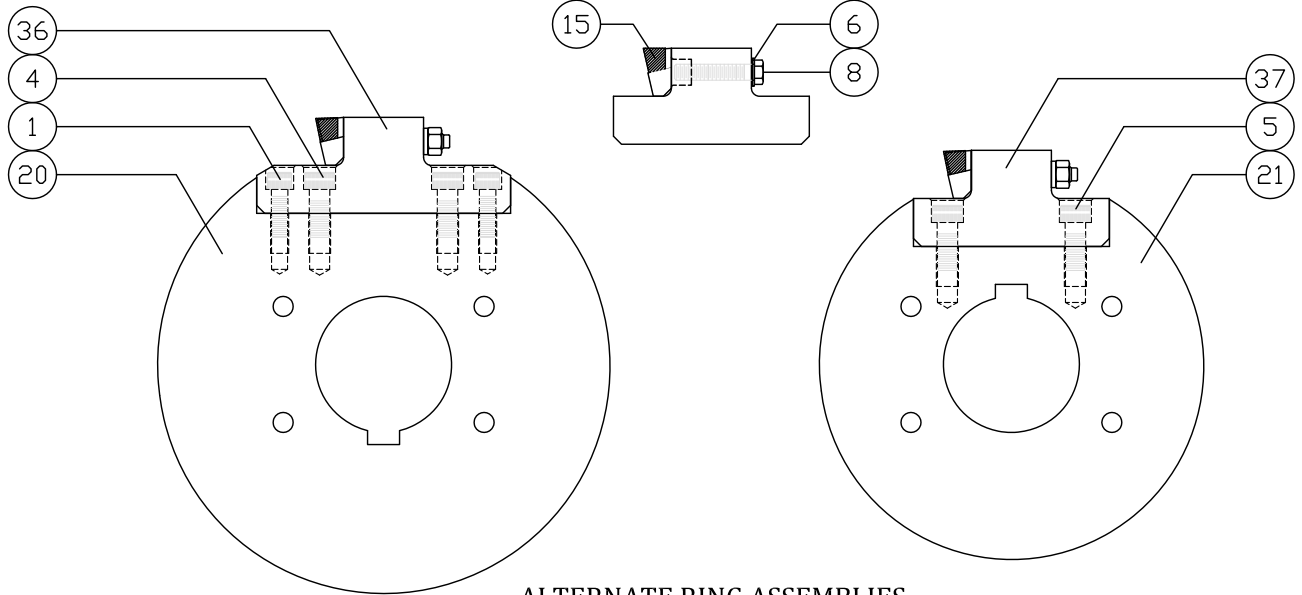

ALTERNATE RING ASSEMBLIES
SHOWING LUG INSERTS IN LIEU OF
FIXED LUG TYPE RINGS.

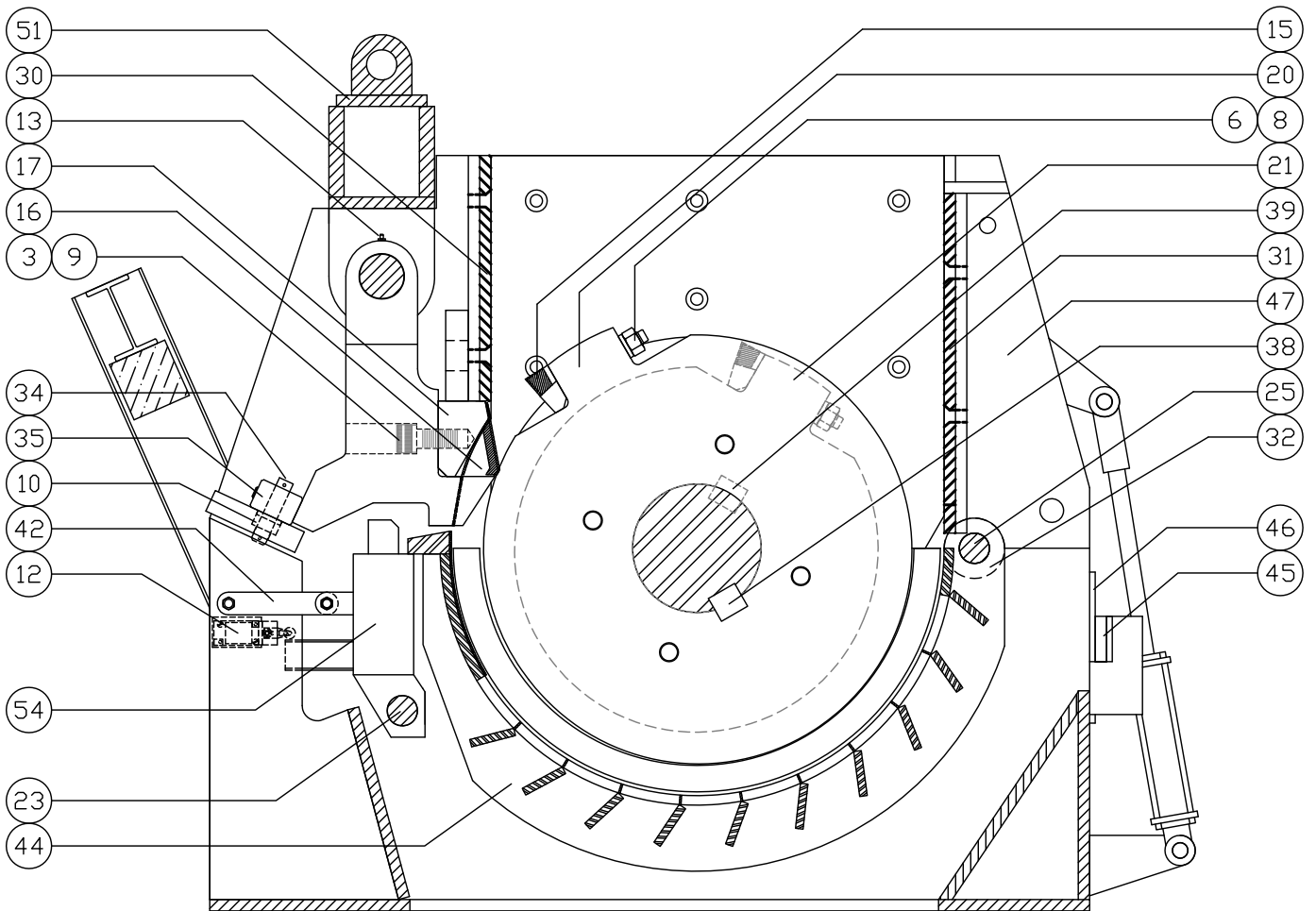

EQUIPMENT: MODEL CS-KC

MONTGOMERY
INDUSTRIES INTERNATIONAL

2017 Thelma Street | PO Box 3687
Jacksonville, Florida 32206 U.S.A.
Ph (904) 355-5671 Fax (904) 355-0401
www.montgomeryindustries.com

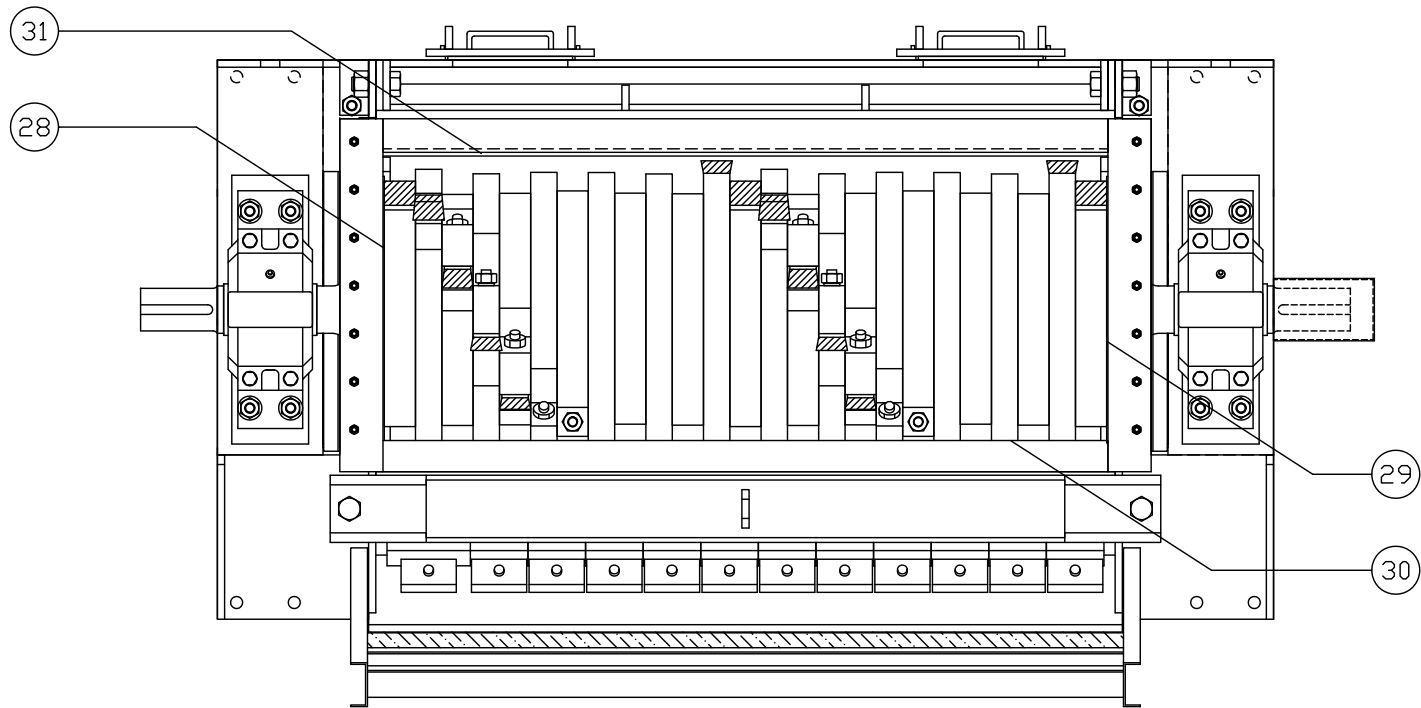

ALTERNATE DOOR
24" FEED OPENING

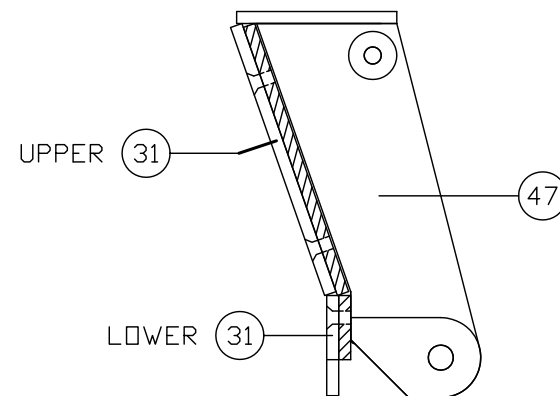
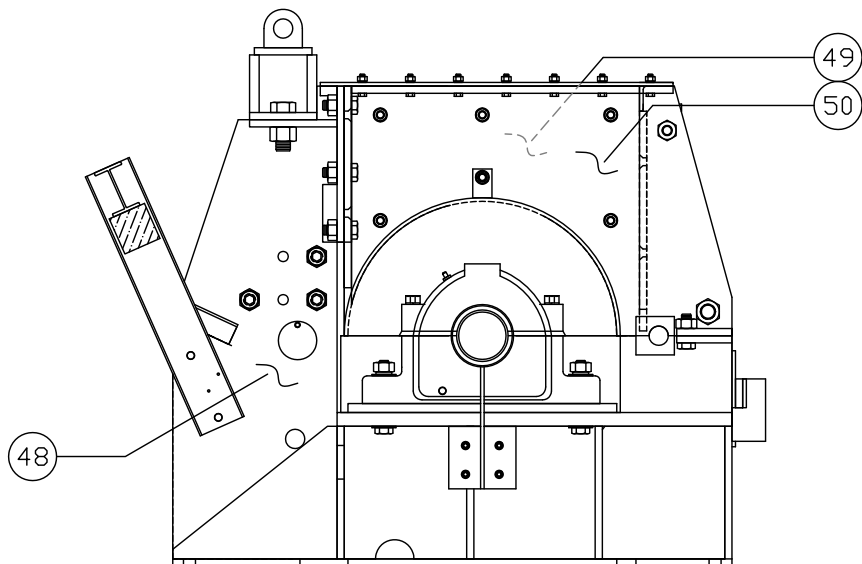

EQUIPMENT: MODEL CS-KC

MONTGOMERY
INDUSTRIES INTERNATIONAL

2017 Thelma Street | PO Box 3687
Jacksonville, Florida 32206 U.S.A.
Ph (904) 355-5671 Fax (904) 355-0401
www.montgomeryindustries.com

MATERIAL LIST

Material List 23-35-93

Refer to Serial Number and Order by Part Number and Description

Phone: 904-355-5671	Fax: 904-355-0401	MONTGOMERY INDUSTRIES INTERNATIONAL 2017 Thelma Street PO Box 3687 Jacksonville, Florida 32206
------------------------	----------------------	---

**GENERIC PARTS LIST – REFERENCE THE PARTS LIST FOR YOUR SERIAL NUMBER FOR
MACHINE-SPECIFIC INFORMATION AND PART QUANTITIES**

Reference	Qty	Part Number	Description
1	VARIES	151-10033	1" X 3" Socket Head Cap Screw (Large Lug Inserts)
2	12	151-10061	1" X 3" Socket Set Screw (End flange)
3	VARIES	151-12533	1-1/4" X 3" Socket Head Cap Screw (Anvil Points)
4	VARIES	151-12533	1-1/4" X 3" Socket Head Cap Screw (Large Lug Inserts)
5	VARIES	151-12533	1-1/4" X 3" Socket Head Cap Screw (Small Lug Inserts)
6	VARIES	152-10001-02	1" 2H Hex Nut Heavy
<i>Alternate</i>	-	152-10005	1" Lock Nut, Heavy Duty Hex <i>(reference 153-10002)</i>
<i>Alternate</i>	-	151-10013	1" X 5" Hex Head Cap Screw (2-Part Tooth)
7	12	152-10004	1" NC Jam Nut (End flange)
8	VARIES	153-10002	1" Lock Washer
<i>Alternate</i>	-	153-10003	1" Flat Washer, Hardened Steel <i>(reference 152-10005)</i>
9	VARIES	153-12502-09	1-1/4" High Collar Lock Washer
10	VARIES	155-03889-2	Bushing, Hardened Steel, 1-3/4" X 1" X 1"
<i>Alternate</i>	-	155-03892-2	Bushing, Hardened Steel, 2" X 1" X 1-1/4"
11	2	181-49301	4-15/16" Bearing (complete) consisting of:
11a	2	181-49302	4-15/16" Pillow Block Housing
11b	2	181-49303	4-15/16" Bearing Unit
11c	2	181-49304	4-15/16" Adapter Assembly
11d	4	181-49305	4-15/16" Oil Seal
11e	1	181-49306	4-15/16" Stabilizing Ring
12	1	185-08021	Limit Switch
13	VARIES	196-16138	#1613-B 1/8" 90 Degree Grease Fitting
14	1	299-00305	Guard Cover for Shaft Extension
15	VARIES	301-03590	KC Tooth
<i>Alternate</i>	-	301-03590-4	KC Tooth, Severe Abrasion
<i>Alternate</i>	-	301-17287	KC 2-Part Tooth
<i>Alternate</i>	-	301-17287-4	KC 2-Part Tooth, Severe Abrasion
16	VARIES	302-03540	Anvil Point, Large, PM-KC & CS-KC Hogs
17	VARIES	302-03541	Anvil Point, Small, PM-KC & CS-KC Hogs
18	VARIES	303-13067	6" Anvil Holder, 1" Bushing, CS-KC Hogs
<i>Alternate</i>	-	303-14651	6" Anvil Holder, 1-1/4" Bushing, CS-KC Hogs
19	1	303-13066	9" Anvil Holder, 1" Bushing, CS-KC Hogs
<i>Alternate</i>	-	303-14650	9" Anvil Holder, 1-1/4" Bushing, CS-KC Hogs
<i>Alternate</i>	-	304-03562	CS-KC Ring, Large, Fixed Lug
20	VARIES	304-04495	CS-KC Ring, Large, Insert Lug

MATERIAL LIST

Material List 23-35-93

Refer to Serial Number and Order by Part Number and Description

Phone: 904-355-5671	Fax: 904-355-0401	MONTGOMERY INDUSTRIES INTERNATIONAL 2017 Thelma Street PO Box 3687 Jacksonville, Florida 32206
------------------------	----------------------	---

**GENERIC PARTS LIST – REFERENCE THE PARTS LIST FOR YOUR SERIAL NUMBER FOR
MACHINE-SPECIFIC INFORMATION AND PART QUANTITIES**

Reference	Qty	Part Number	Description
<i>Alternate</i>	-	304-03563	CS-KC Ring, Small, Fixed Lug
21	VARIES	304-04496	CS-KC Ring, Small, Insert Lug
22	1	305-02004	CS-KC Shaft (Rotor)
23	1	305-04250	Screen Latch Pivot Shaft, KC models
24	1	305-04273	Anvil Rack Shaft for PM-KC & CS-KC Hogs
25	1	305-07731	Screen Pivot Shaft without Keyway, PM-KC & CS-KC Hogs
<i>Alternate</i>	-	305-14628	Screen Pivot Shaft with Keyway for Hyd Reset, PM/CS-KC
26	2	307-04889	End Flange for CS-KC Hogs
27	2	308-04905	Pressure Plate, Shaft, PM-KC, CS-KC, HH Rotors
28	1	308-04636	Wear Plate Over Shaft, L/H (facing Anvil Holders), CS-KC, AR 30" Feed Opening
<i>Alternate</i>	-	308-10129	Wear Plate Over Shaft, L/H (facing Anvil Holders), CS-KC, AR 24" Feed Opening
29	1	308-04638	Wear Plate Over Shaft, R/H (facing Anvil Holders), CS-KC, AR 30" Feed Opening
<i>Alternate</i>	-	308-04852	Wear Plate Over Shaft, R/H (facing Anvil Holders), CS-KC, AR 24" Feed Opening
30	1	308-07710	Wear Plate, Front Door, CS-KC, AR
31	1	308-10119	Wear Plate, Rear Door, CS-KC, AR, 30" Feed Opening
<i>Alternate</i>	-	308-10120 308-10120-U 308-10120-L	Wear Plate, Rear Door, CS-KC, AR, 24" Feed Opening <i>Upper Wear Plate</i> <i>Lower Wear Plate</i>
32	2	309-04576	KC Screen Spacer, 4" O.D. X 1"
33	-	362-14417	Stick Spacer for CS-KC Screens
34	VARIES	314-03760-6	Shear Bolt, 1" X 6", Bronze
<i>Alternate</i>	-	314-13093	Shear Bolt, 1-1/4" X 6", Bronze
35	VARIES	317-13092	Bushing Block, 1", PM-KC & CS-KC Anvil Holders
<i>Alternate</i>	-	317-13437	Bushing Block, 1-1/4", PM-KC & CS-KC Anvil Holders
36	VARIES	320-04497	Insert Lug, Large, CS-KC Ring
37	VARIES	320-04498	Insert Lug, Small, CS-KC Ring
38	VARIES	329-03880	Key, Large CS-KC Ring, 1-1/2" X 2" X 2-3/4"
39	VARIES	329-03881	Key, Small CS-KC Ring, 1-1/2" X 2" X 3-1/4"
40	1	329-03878	Key for Hog Shaft, 1" X 1" X 7" (4-7/16 Shaft Extension)
41	2	329-04136	Split Retaining Ring
42	1	352-04573	Locking Bar for Screen Latch

MATERIAL LIST

Material List 23-35-93

Refer to Serial Number and Order by Part Number and Description

Phone: 904-355-5671	Fax: 904-355-0401	MONTGOMERY INDUSTRIES INTERNATIONAL 2017 Thelma Street PO Box 3687 Jacksonville, Florida 32206
------------------------	----------------------	---

**GENERIC PARTS LIST – REFERENCE THE PARTS LIST FOR YOUR SERIAL NUMBER FOR
MACHINE-SPECIFIC INFORMATION AND PART QUANTITIES**

Reference	Qty	Part Number	Description
43	2	352-05920	Cover for KC Screen Inspection Hole
44	1	362-04841	Baffle Screen for CS-KC Hog
<i>Alternate</i>	-	362-04840	Plate Screen, CS-KC, > 1.25" Holes
<i>Alternate</i>	-	362-11740	M & O Baffle Screen for CS-KC, 4-1/2" Spacing
45	2	363-06392	Locking Bar for Inspection Door
46	2	363-06394	Inspection Door
47	1	363-10117	Rear Door for Model CS-KC, 30" Feed Opening
<i>Alternate</i>	-	363-10118	Rear Door for Model CS-KC, 24" Feed Opening
48	1	367-10116	Lower Housing for Model CS-KC
49	1	367-10124	Upper Housing, CS-KC, L/H, 30" Feed Opening
<i>Alternate</i>	-	367-10124	Upper Housing, CS-KC, L/H, 24" Feed Opening
50	1	367-10125	Upper Housing, CS-KC, R/H, 30" Feed Opening
<i>Alternate</i>	-	367-10125	Upper Housing, CS-KC, R/H, 24" Feed Opening
51	1	369-04457	Anvil Rack Assembly, PM-KC & CS-KC Hogs
52	1	369-04565	Anvil Holder Pressure Plate Assembly, L/H
53	1	369-04566	Anvil Holder Pressure Plate Assembly, R/H
<i>Alternate</i>	-	369-10137	Screen Latch for CS-KC, S/N < 1941
54	1	369-14468	Screen Latch for CS-KC, S/N > 1955