

**MONTGOMERY**  
 INDUSTRIES INTERNATIONAL

2017 Thelma Street | PO Box 3687  
 Jacksonville, Florida 32206 USA  
 Phone: (904) 355-5671 | Fax:  
 (904) 355-0401  
[www.montgomeryindustries.com](http://www.montgomeryindustries.com)

<u>EQUIPMENT:</u>		<b>PM-BH</b>	
<u>MATERIAL LIST:</u>		23-07.23	PAGE <b>1</b> OF <b>5</b>

DETAIL VIEW - ANVIL RACK

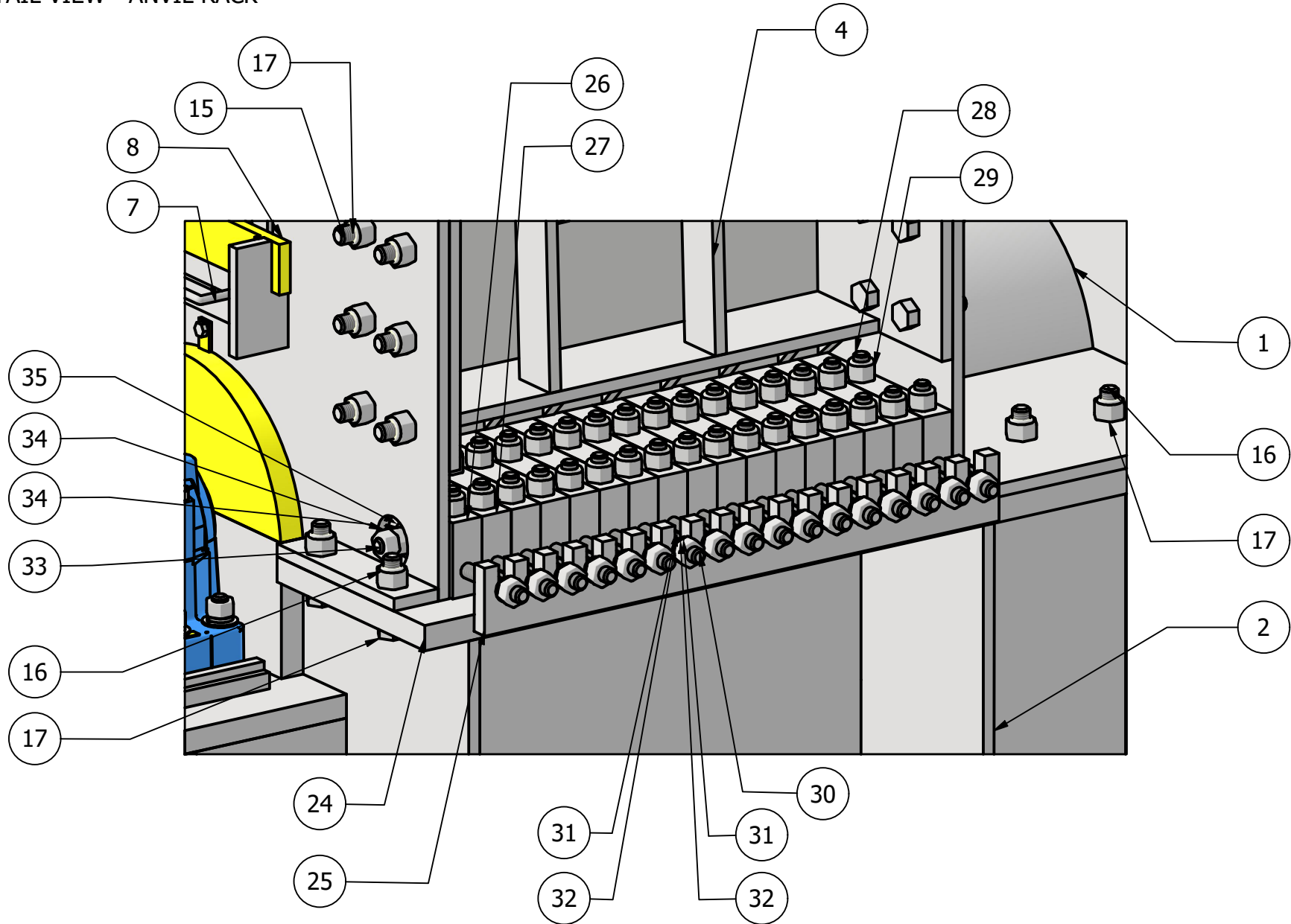

DETAIL VIEW - ROTOR

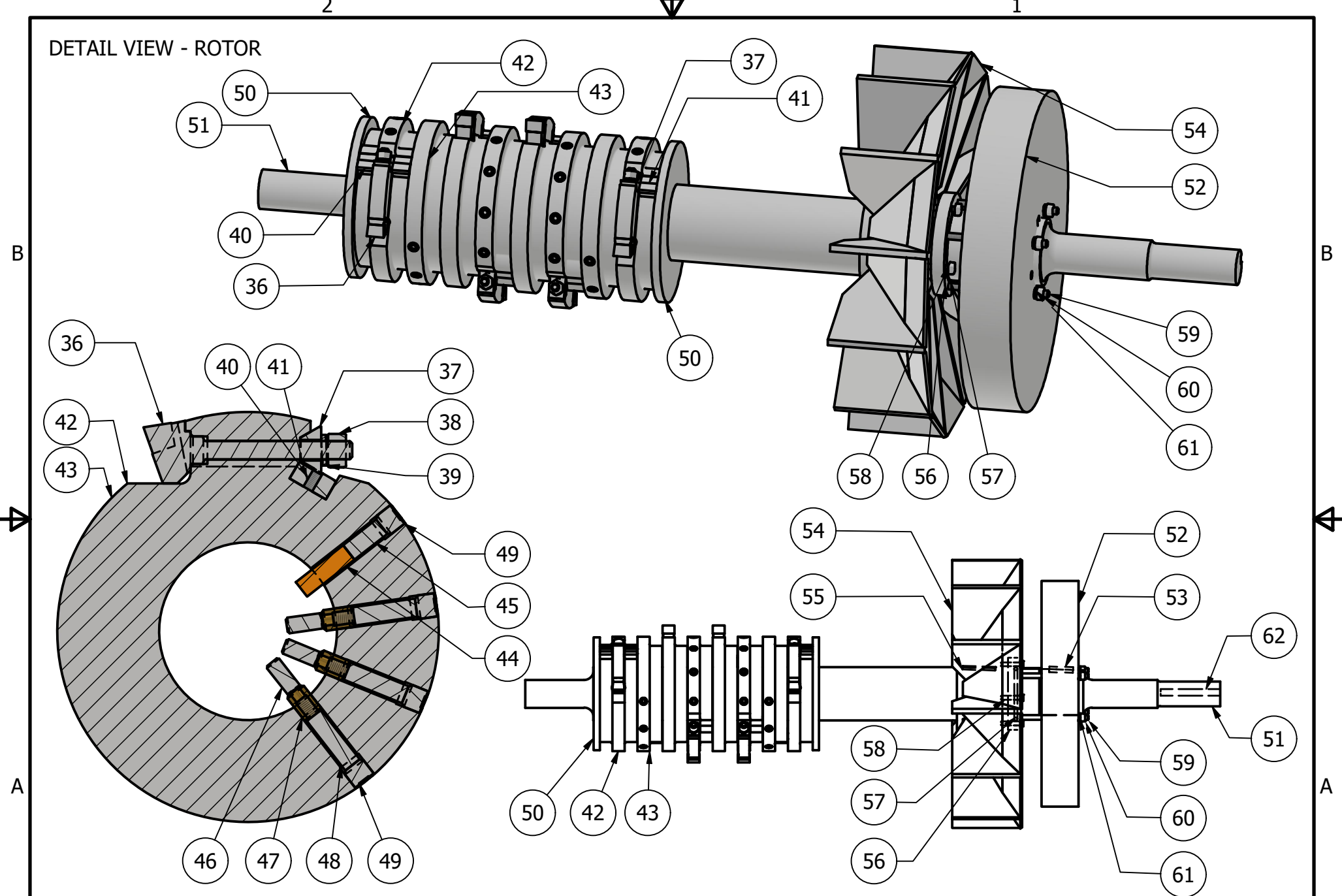

**MONTGOMERY**  
 INDUSTRIES INTERNATIONAL  
 2017 Thelma Street | PO Box 3687  
 Jacksonville, Florida 32206 USA  
 Phone: (904) 355-5671 | Fax:  
 (904) 355-0401  
[www.montgomeryindustries.com](http://www.montgomeryindustries.com)

EQUIPMENT:		<b>PM-BH</b>	
MATERIAL LIST:		23-07.23	PAGE <b>3</b> OF <b>5</b>

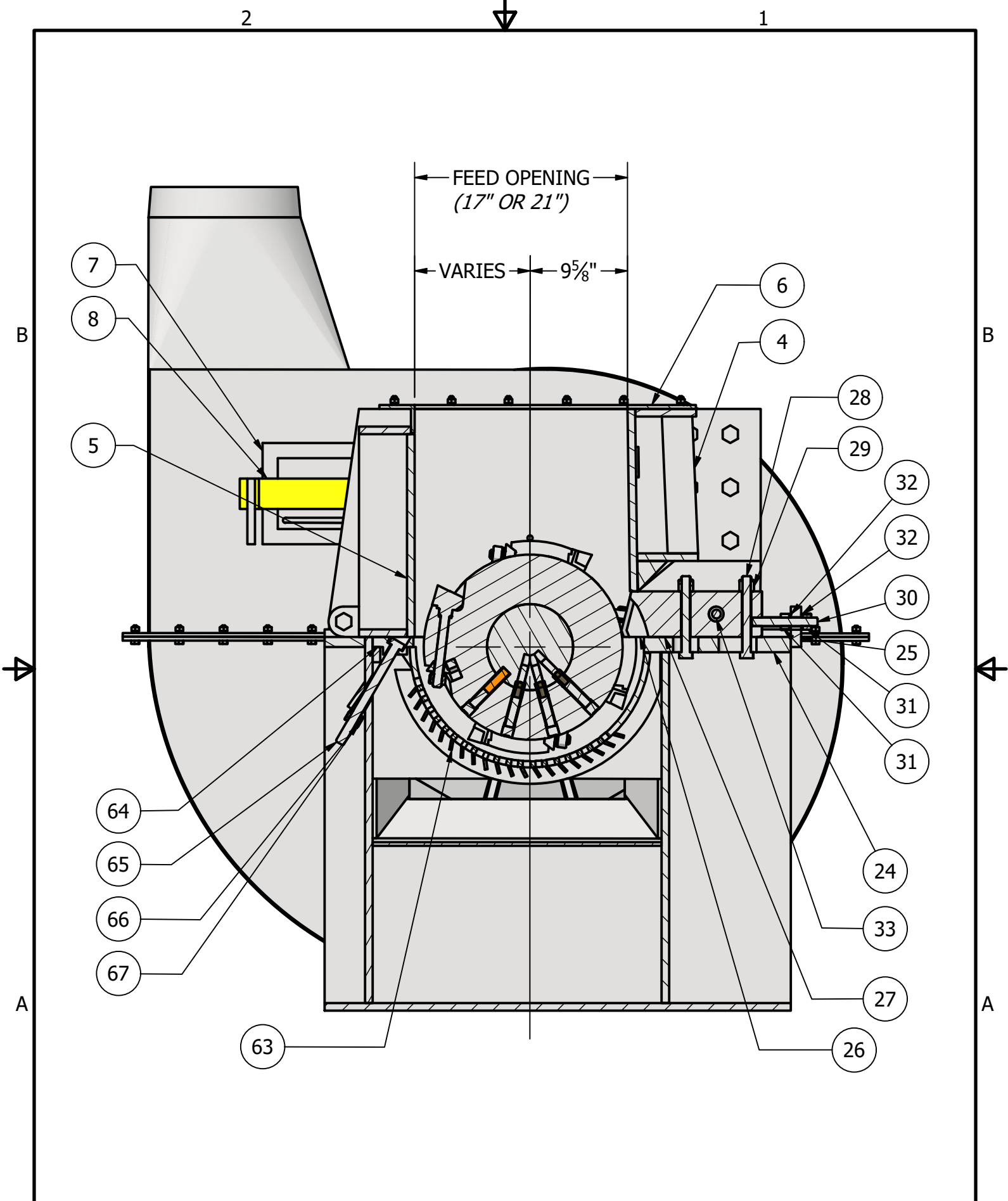

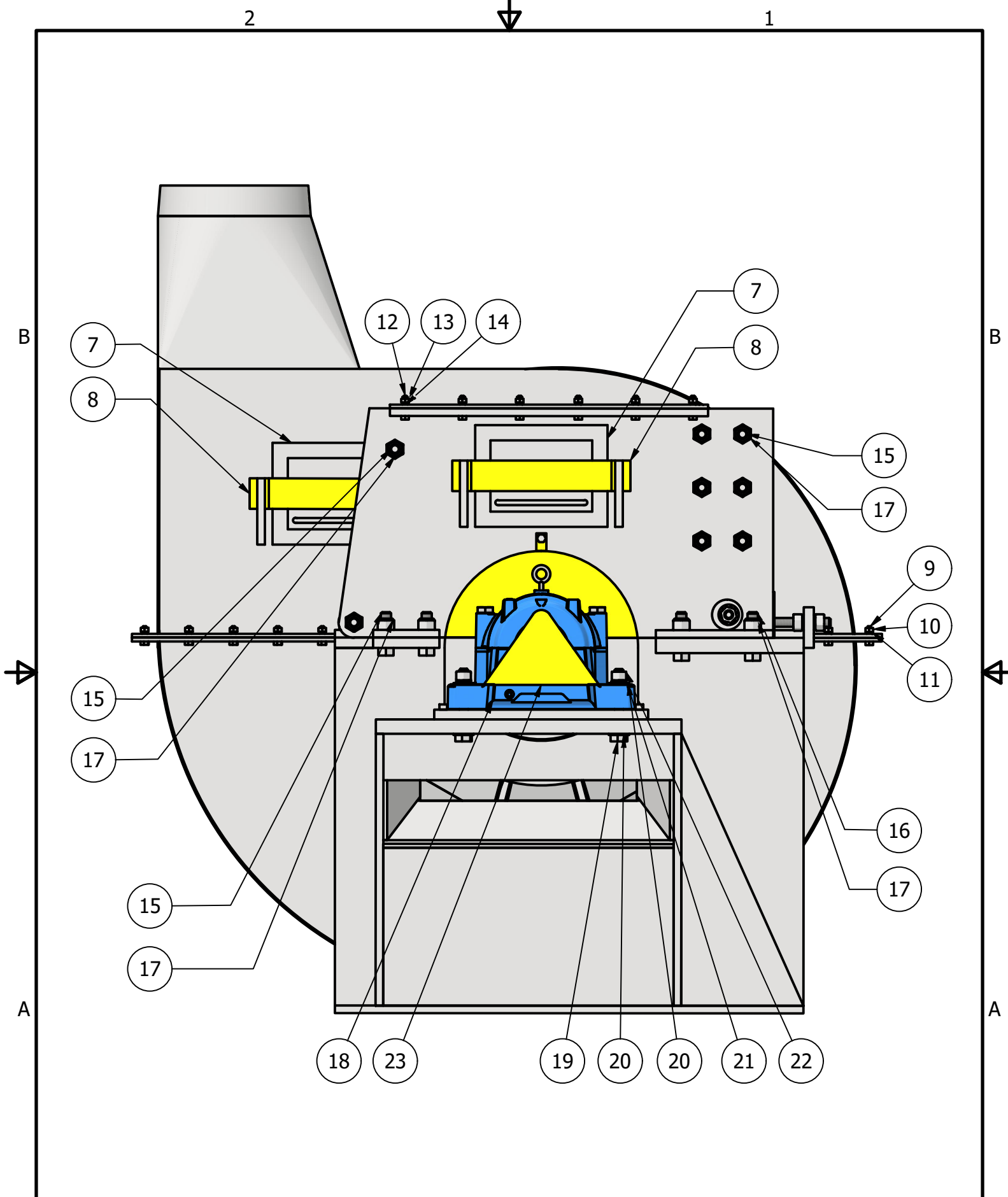



**MONTGOMERY INDUSTRIES INTERNATIONAL**

Phone: 904-355-5671 | Fax: 904-355-0401

2017 Thelma Street PO Box 3687

Jacksonville, Florida 32206

**MATERIAL LIST 23-07.23**



*Refer to Serial Number and Order by Part Number and Description*





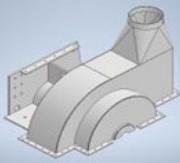
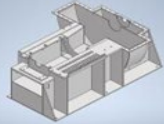
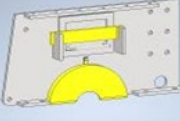
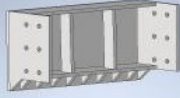
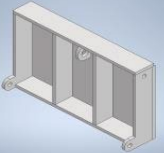

**CUSTOMER:**

**GENERIC PARTS LIST - REFERENCE THE PARTS LIST FOR YOUR SERIAL NUMBER FOR MACHINE-SPECIFIC INFORMATION AND PART QUANTITIES**

REFERENCE	QTY	PART NUMBER	DESCRIPTION	THUMBNAIL	NOTES
-----------	-----	-------------	-------------	-----------	-------

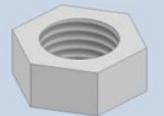
**HOG HOUSING**

1	1	367-09712-40 367-09712-50 367-09712-60	Upper Fan Housing for PM-BH		Part number dependent upon hog size, fan size, & blowpipe size
2	1	367-11370 367-07811 367-13241	PM-BH Lower Housing		Part number dependent upon hog size, fan size, & blowpipe size
3	1	367-09034	PM Upper Housing with Inspection Door		Top flange (for securing companion flange) changes with feed opening. All other components stay the same.
4	1	363-09027	PM Front Door		Not dependent on feed opening
5	1	363-09029	PM Rear Door		Dependent on feed opening
6	1	351-05318 351-05319	PM Companion Flange		Part number dependent on feed opening (17" or 21")

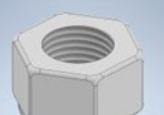
7	2	363-06394	Inspection Door		(1) - PM Upper Housing
					(1) - Upper Fan Housing
8	2	363-06392	Locking Bar for Inspection Door		(1) - PM Upper Housing
					(1) - Upper Fan Housing
9	VARIABLES	151-05005	1/2" X 1-1/2" Hex Head Cap Screw		Secures Upper Fan Housing to Hog Lower Housing
10	VARIABLES	152-05001	1/2" Hex Nut		Secures Upper Fan Housing to Hog Lower Housing
11	VARIABLES	153-05002	1/2" Lock Washer		Secures Upper Fan Housing to Hog Lower Housing
12	12	151-05007	1/2" X 2" Hex Head Cap Screw		Secures Companion Flange to Hog Upper Housing
13	12	152-05001	1/2" Hex Nut		Secures Companion Flange to Hog Upper Housing
14	12	153-05002	1/2" Lock Washer		Secures Companion Flange to Hog Upper Housing
15	20	151-10009	1" X 3-1/2" Hex Head Cap Screw		(12) - Secures Front Door to Upper Housing
					(4) - Secures Rear Door to Upper Housing
					(4) Secures Upper Housing to Lower Housing (Rear)
16	4	151-10011	1" X 4" Hex Head Cap Screw		Secures Upper Housing to Lower Housing (Front)
17	VARIABLES	152-10002-09	1" Nylon Insert Hex Nut		(12) - Secures Front Door to Upper Housing
					(4) - Secures Rear Door to Upper Housing
					(VARIABLES) - Secures Upper Housing to Lower Housing"







18	2	181-44301 181-54301	Bearing (Complete)		Typically 4-7/16" or 5-7/16"; Consists of 18a - 18e
18a	2	181-44302 181-54302	Pillow Block Housing		
18b	2	181-44303 181-54303	Bearing Unit		
18c	2	181-44304 181-54304	Adapter Assembly		Tapered adapter keeps bearing in correct position on shaft
18d	4	181-44305 181-54305	Oil Seal		Oil seals secure lubrication within bearing housing
18e	1	181-44306 181-54306	Stablizing Ring		Only installed on Drive Side
19	8	151-08816 151-10016	Hex Head Cap Screw		Secures Bearings to Hog Housing
20	16	153-08801 153-10001	Flat Washer		Secures Bearings to Hog Housing
21	8	153-08802 153-10002	Lock Washer		Secures Bearings to Hog Housing
22	8	152-08801 152-10001	2H Hex Nut, Heavy		Secures Bearings to Hog Housing
23	1	299-14774	Shaft Extension Guard Cover for Blo-Hogs		Covers the exposed end of the Hog shaft opposite the drive side



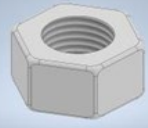
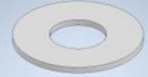

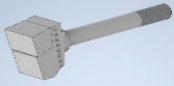
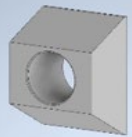
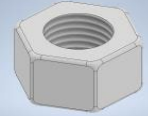

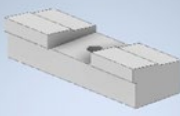
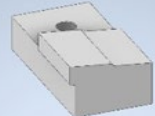

## ANVIL RACK ASSEMBLY

24	1	308-11372 308-07918	PM-BH Anvil Plate		Part number dependent upon hog size & fan size
25	1	364-06900	Anvil Rack		
26	VARIABLES	302-03510	Large F Anvil, Standard Cut		Line up with Inside Teeth on Rotor
27	VARIABLES	302-03511	Small F Anvil		Line up with T3 Teeth on Rotor
28	VARIABLES	151-08820	7/8" X 7-1/2" Square Head Bolt		(2) Per Anvil - secure Anvils to Anvil Plate
29	VARIABLES	152-08802-09	7/8" Nylon Insert Hex Nut		(2) Per Anvil
30	VARIABLES	151-08889	7/8" X 6-1/2" Anvil Stud		(1) Per Anvil - secure Anvils to Anvil Rack
31	VARIABLES	152-08801-02	7/8" 2H Hex Nut, Heavy		For Anvil Studs
32	VARIABLES	153-08805	7/8" Flat Washer - SAE Alloy		For Anvil Studs
33	1	314-06001	Anvil Tie Rod		Runs through Anvils & squeezes them together when tightened

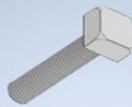

34	4	152-08801-02	7/8" 2H Hex Nut, Heavy		For Anvil Tie Rod
35	2	153-08801	7/8" Flat Washer		For Anvil Tie Rod

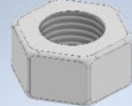
<b>ROTOR</b>					
36	VARIABLES	301-03587	T3 Tooth, Standard Cut		
37	VARIABLES	310-03933	HD Wedge		Secures Inside Teeth Underneath T3 Teeth
38	VARIABLES	152-08801-02	7/8" 2H Hex Nut, Heavy		For T3 Tooth
39	VARIABLES	153-08802	7/8" Lock Washer		For T3 Tooth
40	1	301-03583	1-1/2" X 6" Inside Tooth		For 6" PM-GM Ring
41	VARIABLES	301-03582	1-1/2" X 4" Inside Tooth		For 4" PM-GM Rings
42	1	304-03558	6" PM-GM Ring		
43	VARIABLES	304-03559	4" PM-GM Ring		

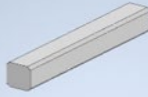
44	VARIABLES	330-03930	Oil Cylinder - 1" Dia. X 2-9/16" Long		(1) Per Ring
45	VARIABLES	311-03941	Spacer - 7/8" X 2" (Oil Cylinder, PM-GM)		(1) Per Ring
46	VARIABLES	151-07565	3/4" NC X 1-3/4" Socket Set Screw		(3) Per Ring - Helps back out Shear Pins when they have been sheared
47	VARIABLES	154-03759-6	Bronze Shear Pin		(3) Per Ring
48	VARIABLES	311-03943	Spacer - 7/8" X 3" (Shear Pin, PM-GM)		(3) Per Ring
49	VARIABLES	151-11355	1-1/8" NF X 1" Socket Set Screw		(4) Per Ring
50	2	307-04530	End Flange for PM Hogs		Welded to outermost rings on Hog Rotor - provide location for balance weights
51	1	305-02002	Blo-Hog Shaft, HD & PM		
52	1	306-04025	6 X 36 BH Flywheel		
53	1	329-03879	Key for Flywheel, 1" X 1" X 4"		Secures Flywheel to Hog Shaft
54	1	293-00040-09 293-00050-09 293-00060-09	Blo-Hog Fanwheel		

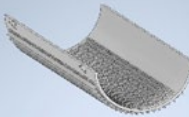
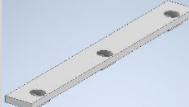
55	1	329-03888	Key for Blo-Hog Fanwheel, 1/2" X 3/4" X 6"		Secures Fanwheel to Hog Shaft
56	1	307-03026	Blo-Hog Flywheel Retaining Flange		
57	1	329-03027	Split Retaining Ring for HD & PM Blo-Hogs		
58	4	151-06376	5/8" NC X 3" Square Head Set Screw		Tightens down Flywheel Retaining Ring to Fanwheel
59	4	314-07598	Flywheel Stud, 3/4" X 12" (6 X 36 Flywheel)		Secures Flywheel to Flywheel Retaining Ring
60	4	152-07501	3/4" Hex Nut, Heavy		Secures Flywheel to Flywheel Retaining Ring
61	4	153-07502	3/4" Lock Washer		Secures Flywheel to Flywheel Retaining Ring
62	1	329-03878	Key for Shaft, 1" X 1" X 7"		Connects Hog Shaft to Direct-Drive Motor

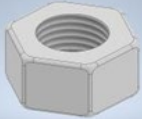
SCREEN					
63	1	362-03410	Screen for PM Hog		Hole Size
					Clearance - Standard/Non-standard
					Baffles/No Baffles
					Plate Thickness - Standard/Non-standard
64	1	308-04002	Screen Clamping Bar		Secures Screen in place

65	VARIES	151-08825	7/8" X 11" Hex Head Cap Screw		Screen Hold Down Bolts - used to tighten down Screen Clamping Bar
66	VARIES	152-08801-02	7/8" 2H Hex Nut, Heavy		Tightens Screen Hold Down Bolts
67	VARIES	153-08802	7/8" Lock Washer		Tightens Screen Hold Down Bolts